

## Inexpensive Y-Block Engine Stand

Want to build a lost cost engine stand for that Y-Block motor you have sitting in the corner of your garage? Or do you need a way to hold a Y-Block engine upright while you're transporting it in the pickup truck. The following is a simple stand made from a single eight foot 2 x 8 and nailed or screwed together. Total cost is about \$7.

Purchase an 8 foot pine 2 x 8 at the local lumber yard. Cut the 2 x 8 into four 2 foot pieces. At the corner of piece "D", one of the 2 foot chunks, cut a  $3\frac{1}{2}$  x  $8\frac{1}{2}$  notch. This notch is required to clear the oil pump at the bottom left of the engine when the engine is in the stand. Arrange the four 2 foot pieces in the manner shown and nail or screw together making sure that pieces "C" and "D" are eight inches apart and parallel.

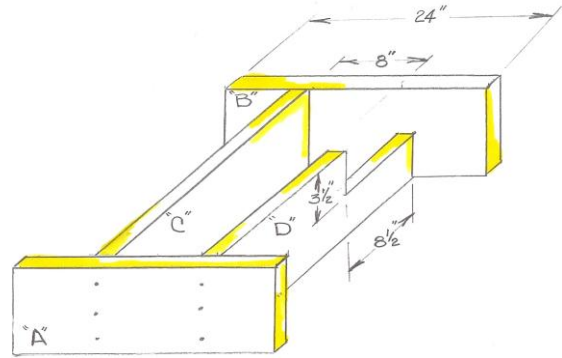

To use the stand set the engine pan into the 2 foot by 8 inch opening in the center. The stand will keep the engine upright. This stand also makes a great base for building a shipping container for a complete engine. Simply cut plywood 24" x 27" for a base and nail the stand to the base. Place 2 - 24" 2 x 4's at each end so that a fork truck can get under the box and then close in the sides and ends with plywood. Place another plywood sheet across the top and band the whole thing together.

I use one of these wood stands when I have an engine out of a car and need to store it or transport it some place. It works great!



Picture of Engine Stand

Respectfully Submitted by Phil Brown 12/2005