

# Thunder Words



October, 2019 ~ Volume 42, #10  
Dedicated to the 55, 56, & 57 Thunderbird  
Nebraskaland Thunderbird Club  
Chapter 65, Classic Thunderbird Club International



## October Club Dinner & Meeting

Thursday, October 24

6:00 pm

[LeRoy's Steak House](#)

710 US-30

North Bend

Hosts: Ted Dimmitt & Fran Graser

*Directions and map on p. 8*

## Prez Says

The weatherman predicted the rain to stop around noon and it did. The sun tried to come out a couple of times but



never made a full recovery. However, by 2:30 pm it turned out to be a perfect day for a Lauritzen Garden guided tour. The gardens are beautiful this time of year. Thanks to **Rob and Vicki Kinsey** for the great arrangements. After the



garden tour, the three Thunderbirds led the fourteen members to El Bees for an enjoyable meal and meeting. During the



[www.Nebraskalandtbirds.org](http://www.Nebraskalandtbirds.org)  
<https://www.facebook.com/nebraskatbirds/>  
Sponsored by [Lee Sapp Ford](#)



drive to El Bees, the different views of Omaha's "L" Street were on full display. Despite the many stop lights along the way, we didn't lose anyone.



Watch for CTCI board member election ballots. Be sure to read the resumes of each candidate before casting your vote.

Fall is officially here and the number of days left to enjoy driving your Bird is getting scarce. Watch your in-boxes for an impromptu driving event during October and maybe a social outing in November. You will receive short notice on each of these events.



Our regular scheduled October meeting is set for 6:00 pm on October 24<sup>th</sup> in North Bend. Our Christmas Party is set for December 14<sup>th</sup>. Make sure your calendars are marked for this event. A head count will be solicited in November.

Unfortunately, the logo patches didn't arrive. Hopefully they will be available for our October meeting.

Still some car events in October. Show off that Bird.

**Jack Sanford**  
*President*

### **Minutes ~ September 29, 2019, Meeting**

The meeting was called to order by the President, **Jack Sanford**, with 14 members and partners present at El Bees in Omaha. Thank you, **Rob and Vicki Kinsey**, for hosting the tour of Lauritzen Gardens, followed by the meeting with dinner at El Bees.



### **Minutes**

A motion to approve the minutes with a correction for the spelling of Woods to Woodman was made by **Marty Bierman** and seconded by **Rob Kinsey**. Carried.

### **CORRECTION**

**Tom Woodman** sold his green '56 T-Bird to **John Stekly**. Both are very happy with the transaction.

**Tom Woodman** drove his T-Bird to Flagstaff for the CTCI convention. Tom was concerned that his T-Bird would go no faster than 80 MPH because he had adjusted the carburetor to be lean for better mileage.

**Tom Woodman** received a trophy at a Lincoln car show.



## Treasurer's Report

**Jeff Brown** was absent so there was no Treasurer's report.



## Old Business

There was interest in having a November meeting so **Marty Bierman** and **Jack Sanford** will work on putting together a meeting. There may be another meeting set up in October.

October meeting hosts will be **Ted Dimmitt** and **Fran Graser** with details to follow.

The Armacost Museum in Grandview, MO, was held on August 24<sup>th</sup>. **Jack Sanford** reported that there were numerous Studebakers on display with a couple of floors of cars, including some Packards and Fords. There was a display in a vintage diner.

The Vintage Wheels at the Fort was held on August 18<sup>th</sup> with T-Birds displayed by **Marty Bierman**, **Jeff Brown**, **Jack Sanford**, and **Gaylan Abood**. It was suggested that maybe this should be a club event next year.



CTCI electronic voting on Director for Region 5 and a Director at Large will start on October 1<sup>st</sup>. **Marty Bierman** suggested that each member carefully review the bios of each of the candidates in the last issue of the Early Bird, then vote.

## New Business

Logo patch sales will be held beginning at the October meeting. The logo is on back order from the supplier.

There will be an opening for the newsletter editor because **Jeff Hoffman** is not going to continue as editor after the December. There was expression of appreciation to **Jeff Hoffman** who was thanked for the terrific job he has done with the newsletter.

See the newsletter for a list of area shows. There are several car events in October and the Wahoo swap meet is on October 13<sup>th</sup>.

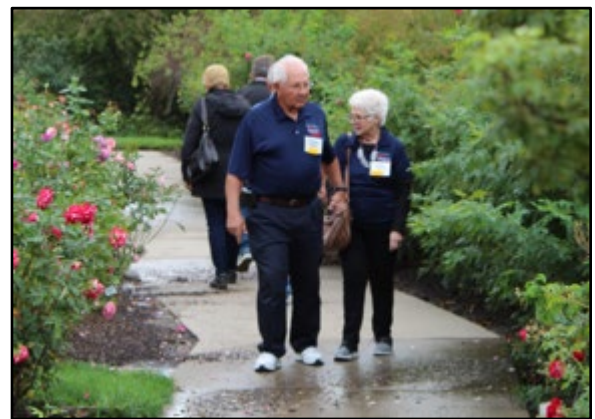

## Announcements

**Jack Sanford** has only a small scar from running into door at the Capitol during our tour at our last meeting

**Marge Schultz** has pneumonia and hopefully she will recover soon.

Birds on the Bay CTCI conference will be held from May 4 – 9, 2020.



[www.Nebraskalandtbirds.org](http://www.Nebraskalandtbirds.org)  
<https://www.facebook.com/nebraskatbirds/>  
Sponsored by [Lee Sapp Ford](#)



## Brag Box

**Jeff Hoffman** and **Jim Lantz** had a very successful car show in New Providence, Iowa: Cruz'n Main Street. Also, they organized a fundraiser that raised \$1,001 for the fire department.

**Jack Sanford** had a monster fish story while on vacation in Utah – a 23" rainbow trout with pictures for proof. Also, his gray T-Bird is running very well now.

## Adjournment

A motion to adjourn the meeting was made by **Marty Bierman** and seconded by **Jim Lantz**. Carried.

Respectably Submitted,  
**Gaylan Abood, Secretary**

## T-Bird Tech Talk

*"Which window regulator goes where?"*

By **Martin Bierman**



**Question** ~ A classic T-Bird owner is completing a restoration and wants to know how to identify which window regulator goes on each side.

**Answer** ~ There are two styles of window regulators: the '55-'56 style and the '57 style which is the improved style. The first picture shows the RH and LH 1957 style window regulators with their respective part numbers 23202-A and 23203-A. Notice that the upper spring ends in the regulator tabs point to the front. This is an easy way to differentiate the RH from the LH side. Note also that the regulators' gears are depicted with the window rolled up stage. With the windows up, the gear on the RH side faces to the front and the LH side faces to the rear. It is easiest to install and remove

the window mechanisms in the window rolled up stage.



The second picture shows an early '55 style LH regulator and the '57 style RH regulator. They differ in that the regulator arm of the later '57 style is longer. The '57 style can be used in a '55-'56 but restorers have suggested relocating the hole at the top of the regulator arm  $\frac{3}{4}$  inch lower. Vendors now sell new '57 style regulators with both holes in the arm so they can be used with either the '55-'56 T-Bird or the '57.



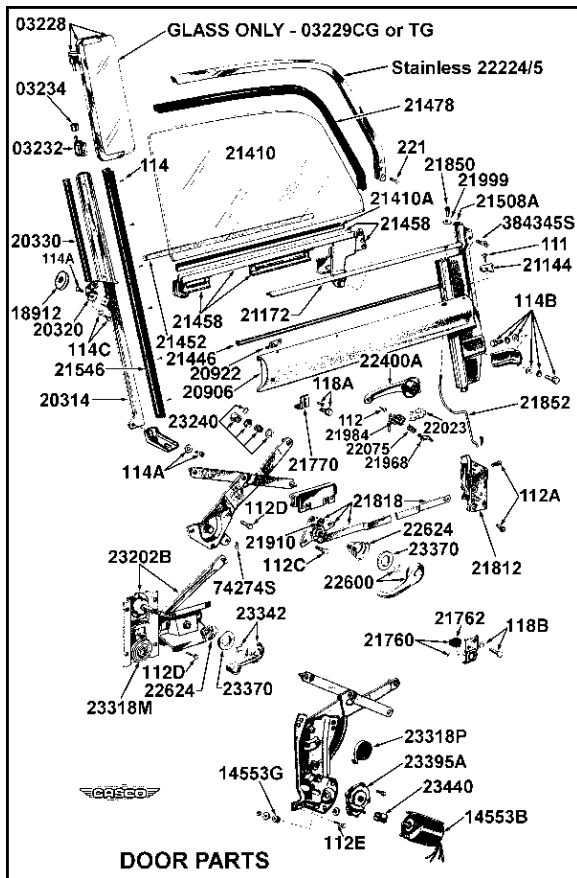

**Nebraskaland Thunderbird Club Meetings and Events**

**October ~ Thursday, October 24 at 6:00 pm. [LeRoy's Steak House](#), 710 US-30, North Bend. Hosts: Ted Dimmitt and Fran Graser.**

**Watch your email for notice of a possible impromptu driving event.**

**November ~ TBD.**

**December ~ Saturday, December 14 at 5:30 pm. Holiday dinner and meeting. [Mahoney State Park](#), Ashland. Hosts: Cathy and Bob McGowan.**

**CTCI Events**

**["Birds on the Bay"](#) International Convention. May 4-9, 2020. Sarasota, FL.**



[www.Nebraskalandtbirds.org](http://www.Nebraskalandtbirds.org)  
<https://www.facebook.com/nebraskatbirds/>  
 Sponsored by [Lee Sapp Ford](#)

**Notice**

Club member **Roger "Jim" Adams** of Fremont passed away September 30. He is survived by his wife, **Betty**. His [obituary](#) is in the October 2<sup>nd</sup> Fremont Tribune. Services were October 5.

**AVAILABLE**

***For Sale – Project Car***

1957 Dusk Rose T-Bird project car. The car is rusty and apart. NOS rear fenders are included (the right side is tacked on) as well as two unrestored hardtops, two radiators with shrouds, and an extra frame. The engine is a 312 with automatic. Multiple other parts and title are also included. Price: \$3600. Contact Jerry Patterson of Iowa at 507-438-9914.



***For Sale – Marvin Wiens's 56 T-Bird***

- Power steering
  - Power brakes
  - 3-speed overdrive transmission
  - Peacock blue
  - Both tops (hard and soft tops)
- Marvin Wiens 402-488-5783



**For Sale – Dick Kirshenbaum’s 55 T-Bird**

- 3-speed overdrive
- Both tops (hard and soft tops)
- Older restoration
- Goldenrod color
- 63,000 miles
- Two owners

Contact [dwkirshenbaum@gmail.com](mailto:dwkirshenbaum@gmail.com) with the pricing information.



**For Sale - Dick Heinke’s 55 T-Bird**

I have come to the painful decision that I want to sell my 55 T-Bird that I totally restored. I have not shown it since 2005 when it won two awards - one in Omaha (the first showing) and a gold in Cleveland. The effort received the 2004 “Best Restoration Award” from the Nebrskaland T-Bird Club.

The odometer has 945 miles on the car since total frame off restoration. The engine is stock except for solid state ignition



module in the distributor (no points). There are many pluses such as 3 speed with overdrive transmission, Halogen headlights, 12 volt alternator and electrical system, dual master cylinder with front disc brakes, extra noise barrier in the underbody paint scheme (foamed enamel) Solid state T-Bird radio AM/FM with cassette player, Stock spoke wheels with 5 white wall radial tires....and more.

I will entertain viewing and will decide on the basis of the successful best offer. A couple years ago, I declined a bid at auction of \$50,000. My phone number is (402) 432-2199. Dick Heinke

**For Sale – Howard Larson’s 57 T-Bird**

Photos and story in the January-February 2019 issue of The Early Bird. Best reasonable offer. Interested parties may contact Howard Larson at 712-281-8812



[www.Nebrskalandtbirds.org](http://www.Nebrskalandtbirds.org)  
<https://www.facebook.com/nebrskatbirds/>  
Sponsored by [Lee Sapp Ford](#)





These embroidered 2 x 3 ½ inch logos can be sewn on or glued with fabric glue onto shirts, jackets, caps, dashboards, etc.

#### Logo Prices

1 logo - \$5	6 logos - \$26
2 logos - \$9	7 logos - \$31
3 logos - \$13	8 logos - \$35
4 logos - \$18	9 logos - \$39
5 logos - \$22	10 logos - \$43



#### Nebraskaland Thunderbird Club

<b>President</b>	<b>Jack Sanford</b>
	402-392-1350 jesanford@cox.net
<b>Vice President</b>	<b>Rob Kinsey</b>
	402-434-9053 rkinsey@krbklaw.com
<b>Treasurer</b>	<b>Jeff Brown</b>
	402-572-1995 fnhog2@gmail.com
<b>Secretary</b>	<b>Gaylan Abood</b>
	402-289-3450 gabood@cox.net
<b>CTCI Rep</b>	<b>John LaDuke</b>
	701-330-7908 sphaeralcea516@gmail.com
<b>Newsletter</b>	<b>Jeff Hoffman</b>
	402-499-6063 ne.thunderbirds@gmail.com
<b>Social Media</b>	<b>Jamie Karl</b>
	402-474-4422 jamiemkarl@gmail.com
<b>Sponsor</b>	<b>Lee Sapp Ford</b>
	402-342-6767 lee@lsford.com

"ThunderWords" is the official publication of the Nebraskaland Thunderbird Club, Chapter 65 of Classic Thunderbird Club International. Annual dues are \$15, payable to Jeff Brown, 7225 S 103<sup>rd</sup> ST, LaVista NE 68128.

#### Hawkeye Classic Thunderbird Club



Panoramic photo by *Mary Lou Bierman*



A copper-plated '55 T-Bird from the 1956 movie "A Kiss Before Dying." It starred Robert Wagner as a college student who kills his rich girlfriend who was a daughter of a copper mine tycoon. The T-Bird is copper-colored and, supposedly, copper plated. It had a Thunderbird Blue interior.

Submitted by *Martin Bierman*



[www.Nebraskalandtbirds.org](http://www.Nebraskalandtbirds.org)  
<https://www.facebook.com/nebraskatbirds/>  
 Sponsored by [Lee Sapp Ford](#)



## Directions and Map

**October Club Dinner & Meeting**

**Thursday, October 24 at 6:00 pm**

**LeRoy's Steak House**

**710 US-30, North Bend**

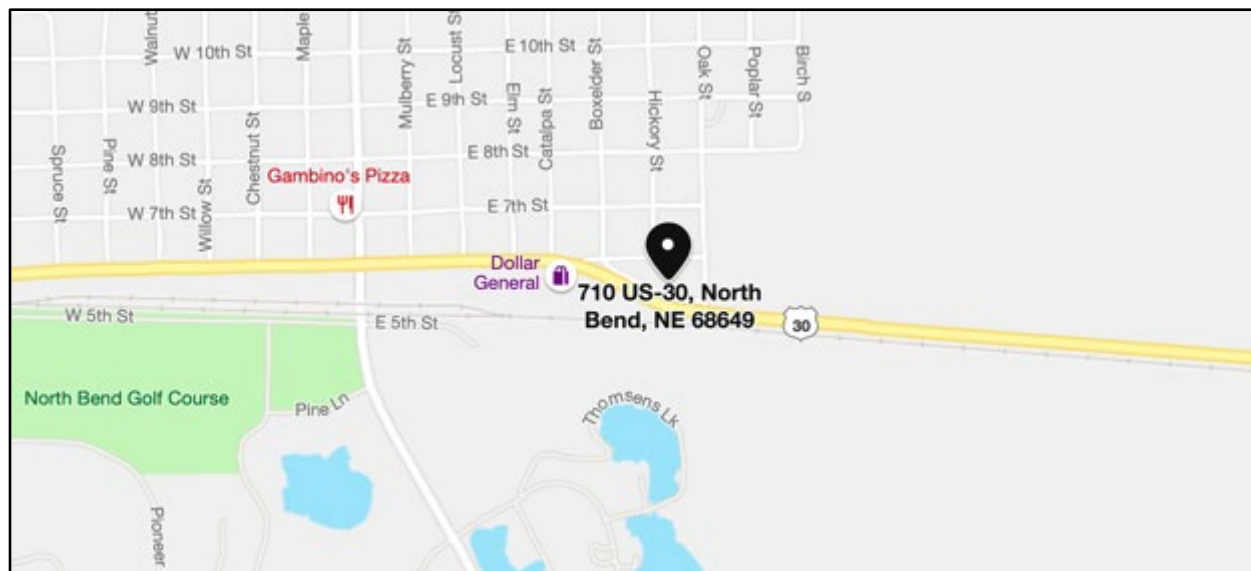

### **From Omaha**

Take Hwy 6/West Dodge west to Hwy 275  
Turn right/north onto Hwy 275.  
Continue on Hwy 275 to Fremont.  
Continue on Hwy 275/Hwy 30 to the north side of Fremont.  
Continue on Hwy 30 to North Bend.

### **From Lincoln**

Take I-180/Hwy 34 north.  
Follow Hwy 34 to Hwy 79.  
Turn right/north onto Hwy 79  
Continue on Hwy 79 to Hwy 30 in North Bend.  
Turn right/east onto Hwy 30.

**YOU CAN'T BUY HAPPINESS  
BUT YOU CAN BUY A *THUNDERBIRD*  
AND THAT'S ABOUT THE SAME THING**



[www.Nebraskalandtbirds.org](http://www.Nebraskalandtbirds.org)  
<https://www.facebook.com/nebraskatbirds/>  
Sponsored by Lee Sapp Ford

